

# Discovering Cells

## Reading Preview

### Key Concepts

- What are cells?
- How did the invention of the microscope contribute to knowledge about living things?
- What is the cell theory?
- How do microscopes produce magnified images?

### Key Terms

- cell
- microscope
- cell theory

## Target Reading Skill

**Sequencing** A sequence is the order in which a series of events occurs. As you read, construct a flowchart showing how the work of Hooke, Leeuwenhoek, Schleiden, Schwann, and Virchow contributed to scientific understanding of cells.

### Discovering Cells

Hooke sees cells in cork.



Lab  
zone

## Discover Activity

### Is Seeing Believing?

1.  Cut a black-and-white photograph out of a page in a newspaper. With only your eyes, closely examine the photo. Record your observations.
2. Examine the same photo with a hand lens. Again, record your observations.
3. Place the photo on the stage of a microscope. Use the clips to hold the photo in place. Shine a light down on the photo. Focus the microscope on part of the photo. (See Appendix B for instructions on using the microscope.) Record your observations.



### Think It Over

**Observing** What did you see in the photo with the hand lens that you could not see with only your eyes? What additional details could you see with the microscope?

A forest is filled with an amazing variety of living things. Some are easy to see, but you have to look closely to find others. If you look carefully at the floor of a forest, you can often find spots of bright color. A beautiful pink coral fungus grows beneath tall trees. Beside the pink fungus, a tiny red newt perches on a fallen leaf.

What do you think a fungus, a tree, and a red newt have in common? They are all living things, or organisms, and, like all organisms, they are made of cells.

FIGURE 13

**Newt and Coral Fungus**  
All living things are made of cells, including this pink fungus and the red newt that perches next to it.



## An Overview of Cells

You are made of cells. **Cells are the basic units of structure and function in living things.** This means that **cells** form the parts of an organism and carry out all of an organism's processes, or functions.

**Cells and Structure** When you describe the structure of an object, you describe what it is made of and how its parts are put together. The structures of many buildings, for example, are determined by the way in which bricks, steel beams, and other materials are arranged. The structures of living things are determined by the amazing variety of ways in which cells are put together. A tall tree, for example, consists of cells arranged to form a high trunk and leafy branches. A red newt's cells form a body with a head and four legs.

**Cells and Function** An organism's functions are the processes that enable it to stay alive and reproduce. Some functions in organisms include obtaining oxygen, getting rid of wastes, obtaining food, and growing. Cells are involved in all these functions. For example, cells in your digestive system absorb food. The food provides your body with energy and materials needed for growth.

**Many and Small** Figure 14 shows human skin cells. One square centimeter of your skin's surface contains more than 100,000 cells. But no matter how closely you look with your eyes alone, you won't be able to see individual skin cells. That is because, like most cells, those of your skin are very small. Until the late 1600s, no one knew cells existed because there was no way to see them.



What are some functions that cells perform in living things?

## First Observations of Cells

Around 1590, the invention of the microscope enabled people to look at very small objects. **The invention of the microscope made it possible for people to discover and learn about cells.** A **microscope** is an instrument that makes small objects look larger. Some microscopes do this by using lenses to focus light. The lenses used in light microscopes are similar to the clear, curved pieces of glass or plastic used in eyeglasses. A simple microscope contains only one lens. A light microscope that has more than one lens is called a compound microscope.

FIGURE 14  
Skin Cells

Your skin is made of cells such as these. **Applying Concepts** What are cells?

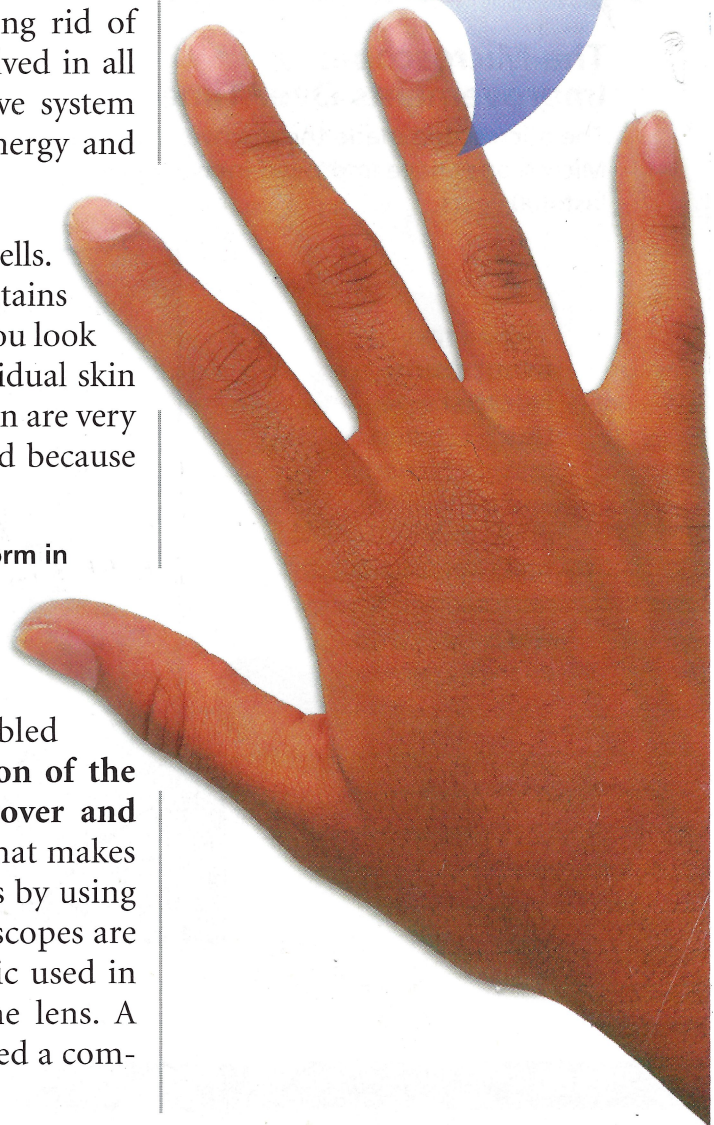

**Robert Hooke** One of the first people to observe cells was the English scientist and inventor Robert Hooke. Hooke built his own compound microscope, which was one of the best microscopes of his time. In 1663, Hooke used his microscope to observe the structure of a thin slice of cork. Cork, the bark of the cork oak tree, is made up of cells that are no longer alive. To Hooke, the empty spaces in the cork looked like tiny rectangular rooms. Therefore, Hooke called the empty spaces *cells*, which is a word meaning “small rooms.”

Hooke described his observations this way: “These pores, or cells, were not very deep, but consisted of a great many little boxes. . . .” What most amazed Hooke was how many cells the cork contained. He calculated that in a cubic inch there were about twelve hundred million cells—a number he described as “almost incredible.”

## Tech & Design in History

### The Microscope: Improvements Over Time

The microscope made the discovery of cells possible. Microscopes have improved in many ways over the last 400 years.

#### 1590 First Compound Microscope

Dutch eyeglass makers Zacharias and Hans Janssen made one of the first compound microscopes. It was a tube with a lens at each end.

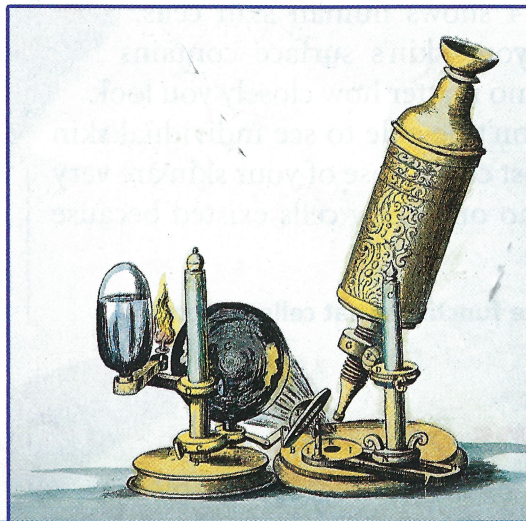
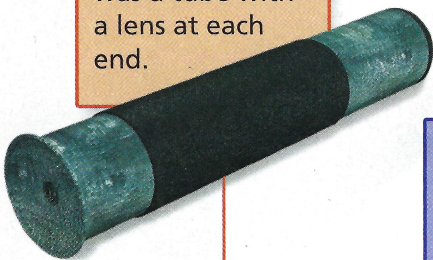

#### 1660 Hooke's Compound Microscope

Robert Hooke's compound microscope included an oil lamp for lighting. A lens focuses light from the flame onto the specimen.

#### 1674 Leeuwenhoek's Simple Microscope

Although Anton Von Leeuwenhoek's simple microscope used only one tiny lens, it could magnify a specimen up to 266 times.

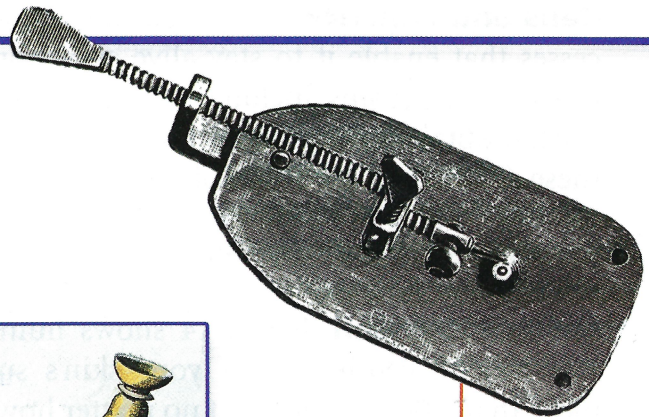

1500

1600

1700

**Anton van Leeuwenhoek** At about the same time that Robert Hooke made his discovery, Anton van Leeuwenhoek (LAY vun hook) also began to observe tiny objects with microscopes. Leeuwenhoek was a Dutch businessman who sold cloth. In his spare time, he built simple microscopes.

Leeuwenhoek looked at drops of lake water, scrapings from teeth and gums, and water from rain gutters. In many materials, Leeuwenhoek was surprised to find a variety of one-celled organisms. Leeuwenhoek noted that many of these tiny organisms moved. Some whirled, some hopped, and some shot through water like fast fish. He called these moving organisms *animalcules* (an ih MAL kyoolz), meaning “little animals.”



Which type of microscope—simple or compound—did Leeuwenhoek make and use?

## Writing in Science

**Research and Write** Find out more about one of the microscopes. Then write an advertisement for it that might appear in a popular science magazine. Be creative. Emphasize the microscope’s usefulness or describe the wonders that can be seen with it.

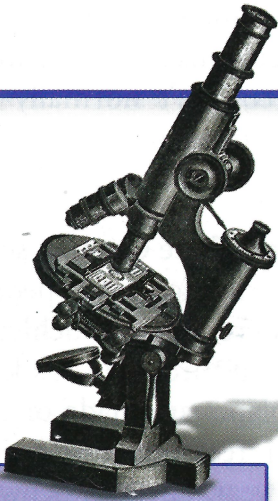

### 1886 Modern Compound Light Microscope

German scientists Ernst Abbé and Carl Zeiss made a compound light microscope with complex lenses that greatly improved the image. A mirror focuses light up through the specimen. Modern compound microscopes can effectively magnify a specimen up to 1,000 times.

### 1965 Scanning Electron Microscope (SEM)

An SEM sends electrons over the surface of a specimen, rather than through it. The result is a three-dimensional image of the specimen’s surface. SEMs can magnify a specimen up to 150,000 times.

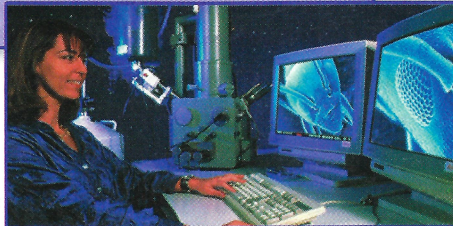

### 1981 Scanning Tunneling Microscope (STM)

An STM measures electrons that leak, or “tunnel,” from the surface of a specimen. STMs can magnify a specimen up to 1,000,000 times.

### 1933 Transmission Electron Microscope (TEM)

German physicist Ernst Ruska created the first electron microscope. TEMs send electrons through a very thinly sliced specimen. TEMs can magnify a specimen up to 500,000 times.

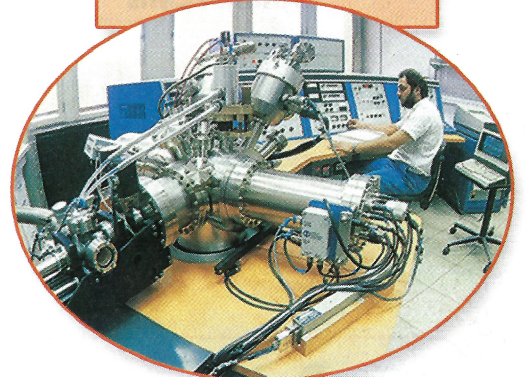

1800

1900

2000

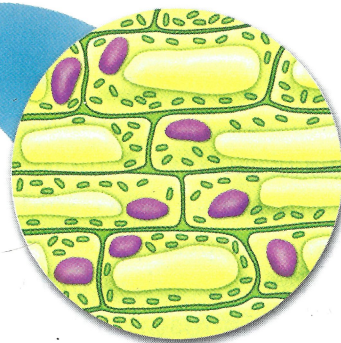

**Plant Cells**

**FIGURE 15**  
**Monarch and Milkweed**  
The monarch butterfly caterpillar and the milkweed leaf that the caterpillar nibbles on are both made of cells.

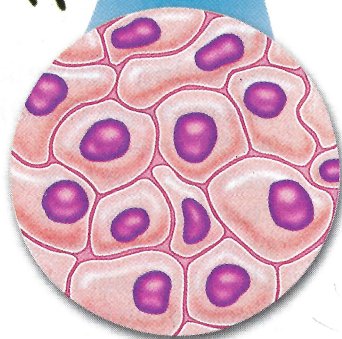

**Animal Cells**

## Development of the Cell Theory

Leeuwenhoek's exciting discoveries caught the attention of other researchers. Like Hooke, Leeuwenhoek, and all good scientists, these other researchers were curious about the world around them, including things they couldn't normally see. Many other people began to use microscopes to discover what secrets they could learn about cells.

**Schleiden, Schwann, and Virchow** Three German scientists made especially important contributions to people's knowledge about cells. These scientists were Matthias Schleiden (SHLY dun), Theodor Schwann, and Rudolf Virchow (FUR koh). In 1838, Schleiden concluded that all plants are made of cells. He based this conclusion on his own research and on the research of others before him. The next year, Theodor Schwann concluded that all animals are also made up of cells. Thus, stated Schwann, all living things are made up of cells.

Schleiden and Schwann had made an important discovery about living things. However, they didn't explain where cells came from. Until their time, most people thought that living things could come from nonliving matter. In 1855, Virchow proposed that new cells are formed only from cells that already exist. "All cells come from cells," wrote Virchow.

**What the Cell Theory Says** Schleiden, Schwann, Virchow, and others helped develop the cell theory. The **cell theory** is a widely accepted explanation of the relationship between cells and living things. **The cell theory states the following:**

- All living things are composed of cells.
- Cells are the basic units of structure and function in living things.
- All cells are produced from other cells.

**Go Online**

SCILINKS<sup>™</sup>  
NSTA

For: Links on cell theory  
Visit: [www.SciLinks.org](http://www.SciLinks.org)  
Web Code: scn-0311

The cell theory holds true for all living things, no matter how big or how small. Since cells are common to all living things, they can provide information about the functions that living things perform. Because all cells come from other cells, scientists can study cells to learn about growth and reproduction.

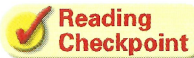
**Reading  
Checkpoint**

What did Schleiden and Schwann conclude about cells?

## Light and Electron Microscopes

The cell theory could not have been developed without microscopes. For a microscope to be useful, it must combine two important properties—magnification and resolution. Scientists today use two kinds of microscopes: light microscopes and electron microscopes.

**Magnification and Lenses** The first property, magnification, is the ability to make things look larger than they are. **The lenses in light microscopes magnify an object by bending the light that passes through them.** If you examine a hand lens, such as the one in Figure 16, you will see that the lens is curved, not flat. The center of the lens is thicker than the edge. A lens with this curved shape is called a convex lens. The light passing through the sides of the lens bends inward. When this light hits the eye, the eye sees the object as larger than it really is.

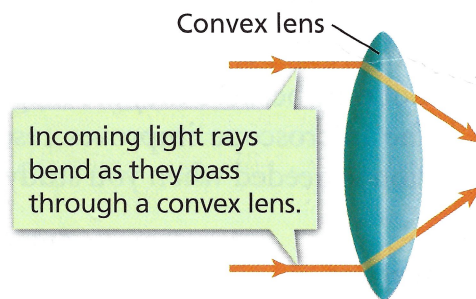



FIGURE 16

### A Convex Lens

A magnifying glass is a convex lens. The lines in the diagram represent rays of light, and the arrows show the direction in which the light travels.

**Interpreting Diagrams** Describe what happens to light rays as they pass through a convex lens.

### Observing

1. Read about using the microscope (Appendix B) before beginning this activity.
2.  Place a prepared slide of a thin slice of cork on the stage of a microscope.
3. Observe the slide under low power. Draw what you see.
4. Place a few drops of pond water on another slide and cover it with a coverslip.
5. Observe the slide under low power. Draw what you see. Wash your hands after handling pond water.

How does your drawing in Step 3 compare to Hooke's description of cells on page 52? Based on your observations in Step 5, why did Leeuwenhoek call the organisms he saw "little animals"?



**FIGURE 17 A Compound Microscope**

A compound microscope has two convex lenses. **Calculating** If one lens has a magnification of 10, and the other lens has a magnification of 50, what is the total magnification?

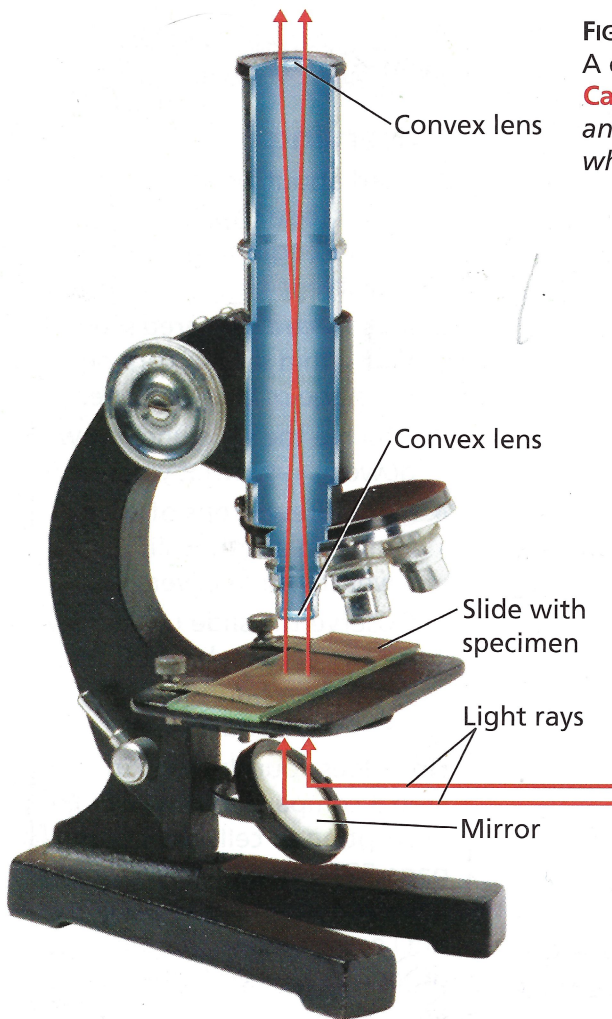

### Compound Microscope Magnification

A compound microscope uses more than one lens. As a result, it can magnify an object more than one lens by itself. Light passes through a specimen and then through two lenses, as shown in Figure 17. The first lens, near the specimen, magnifies the object. Then a second lens, near the eye, further magnifies the enlarged image. The total magnification of the microscope is equal to the magnifications of the two lenses multiplied together. For example, suppose the first lens makes an object look 10 times bigger than it actually is, and the second lens makes the object look 40 times bigger than it actually is. The total magnification of the microscope is  $10 \times 40$ , or 400.

**Resolution** To create a useful image, a microscope must also help you see individual parts clearly. The ability to clearly distinguish the individual parts of an object is called resolution. Resolution is another term for the sharpness of an image. For example, a photograph in a newspaper is really made up of a collection of small dots. If you put the photo under a microscope, you can see the dots. You see the dots not only because they are magnified but also because the microscope improves resolution. Good resolution is needed when you study cells.

**FIGURE 18**

### Light Microscope Photos

The pictures of the water flea and the threadlike *Spirogyra* were both taken with a light microscope.

**Water flea**  
40 times actual size



***Spirogyra***  
300 times actual size

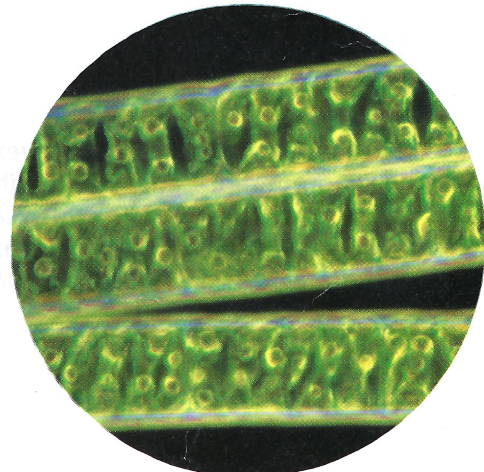
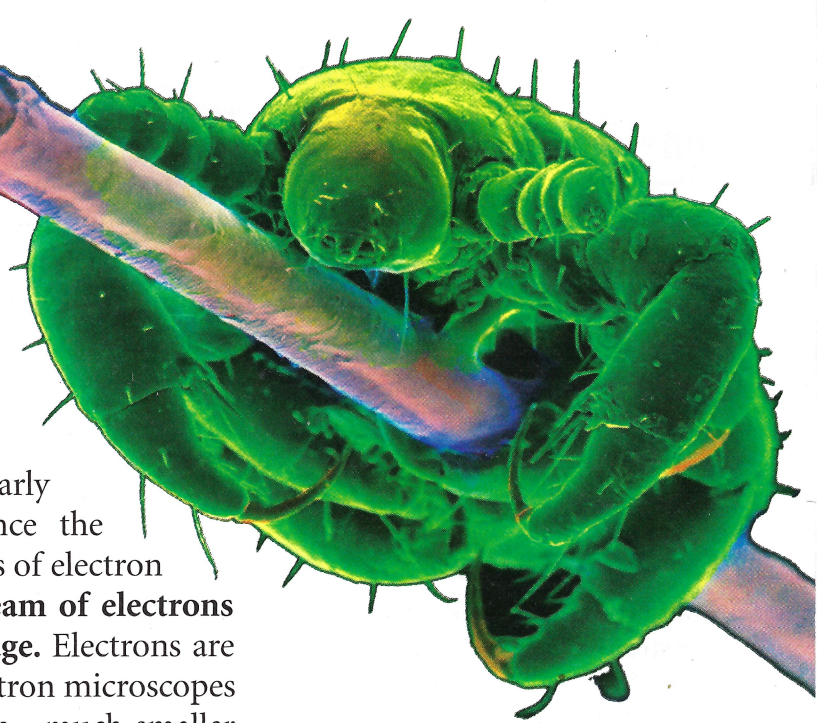

FIGURE 19

**Electron Microscope Picture**

A head louse clings to a human hair. This picture was taken with a scanning electron microscope. The louse has been magnified to more than 100 times its actual size.



**Electron Microscopes** The microscopes used by Hooke, Leeuwenhoek, and other early researchers were all light microscopes. Since the 1930s, scientists have developed different types of electron microscopes. **Electron microscopes use a beam of electrons instead of light to produce a magnified image.** Electrons are tiny particles that are smaller than atoms. Electron microscopes can obtain pictures of extremely small objects—much smaller than those that can be seen with light microscopes. The resolution of electron microscopes is much better than the resolution of light microscopes.

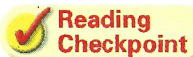

What do electron microscopes use to produce magnified images?

## Section 3 Assessment

**Target Reading Skill Sequencing** Review your flowchart and use it to answer Questions 2 and 3 below.

### Reviewing Key Concepts

- Defining** Define *structure* and *function*.
  - Explaining** Explain this statement: Cells are the basic units of structure and function in organisms.
  - Applying Concepts** In what important function are the cells in your eyes involved?
- Reviewing** What does a microscope enable people to do?
  - Summarizing** Summarize Hooke's observations of cork under a microscope.
  - Relating Cause and Effect** Why would Hooke's discovery have been impossible without a microscope?
- Reviewing** What are the main ideas of the cell theory?
  - Explaining** What did Virchow contribute to the cell theory?

- Applying Concepts** Use the ideas of Virchow to explain why plastic plants and stuffed animals are not alive.
- Defining** What is magnification?
  - Comparing and Contrasting** Contrast the way light microscopes and electron microscopes magnify objects.

### Writing in Science

**Writing an Award Speech** Suppose you are a member of a scientific society that is giving an award to one of the early cell scientists. Choose the scientist, and write a speech that you might give at the award ceremony. Your speech should describe the scientist's accomplishments.